

Een nieuw document openen met een program editor

- Druk op de Home knop (🏠).
- Kies 1: New Document.
- Kies vervolgens:
 - 9: Add Program Editor
 - 1:New

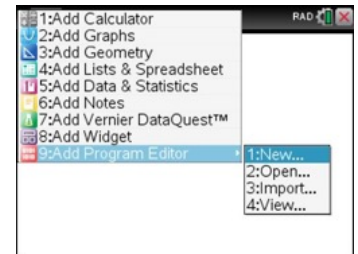

Voer de naam van het programma in. De andere gegevens kunnen als default blijven ingesteld.

Om een nieuwe program in een document aan te maken, voer bijvoorbeeld eerst een nieuwe pagina in (Ctrl+I) en kies vervolgens 9: Add Program Editor en 1: New.



Een programma uitvoeren

- Sla het programma op met ctrl B en selecteer 3: Run (ctrl R).
- Een Calculator App opent automatisch en het programma staat klaar om uit te voeren. Druk ENTER.



- Een programma kan ook rechtstreeks uitgevoerd worden vanuit de Calculator door het programma in te tikken, color(), of te selecteren door op de VAR-knop te drukken.

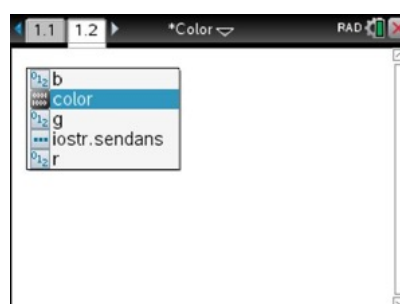

Knipperend Lichtje

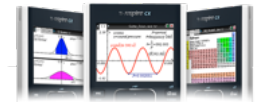

1. Creëer een nieuw programma light: druk Home (⏠), kies 1: New Document en vervolgens 9: Add Program Editor en 1:New.

2. Druk Menu > Hub > Send "SET en selecteer LIGHT.

```
Define light()=
Prgm
Send "SET LIGHT"
EndPrgm
```

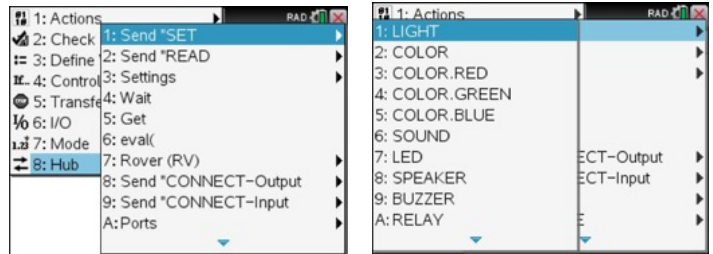

3. Selecteer in het Hub-submenu Settings ON, selecteer dan BLINK en type 10:

```
Define light()=
Prgm
Send "SET LIGHT ON BLINK 10"
EndPrgm
```

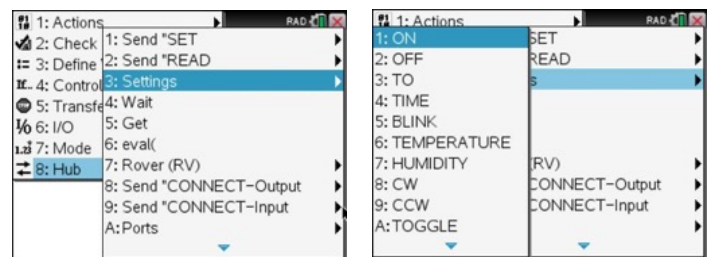

4. Selecteer TIME in het Hub-submenu, Settings en type 1.

5. Vervolg met Wait en type 2.

6. Eindig het programma met Send "SET LIGHT OFF".

7. Bewaar het programma light en run light in een Calculator Applicatie.

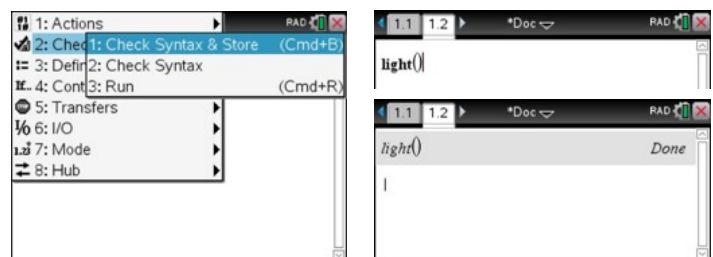
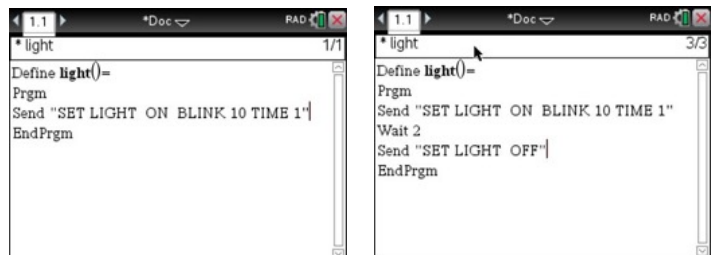

```
Define light()=
Prgm
Send "SET LIGHT ON BLINK 10 TIME 1"
Wait 2
Send "SET LIGHT OFF"
EndPrgm
```



Geluid Maken



1. Creëer een nieuw programma geluid: druk Home (⌂), kies 1: New Document en vervolgens 9: Add Program Editor en 1:New.

2. Druk Menu > I/O > Request en voer de volgende code in:
Request "Geef de frequentie (100-4000)",f
Request "Geef de tijdsduur (1-5)",t

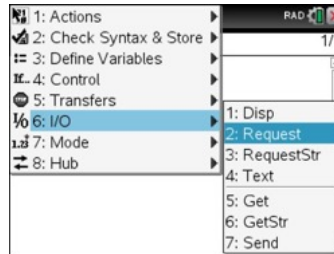

3. Druk Menu > Hub > Send "SET en selecteer SOUND.
Request "Geef de frequentie (100-4000)",f
Request "Geef de tijdsduur (1-5)",t
Send "SET SOUND|"

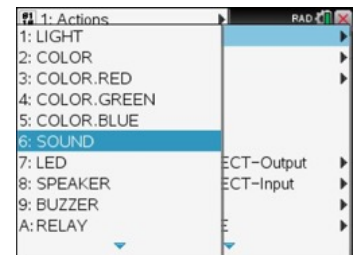
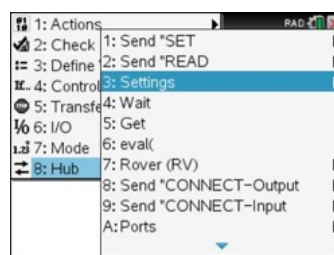

4. Selecteer eval(in het Hub menu, type f en vul aan met eval(t).

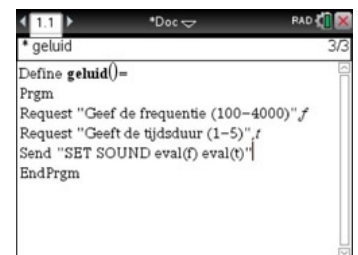
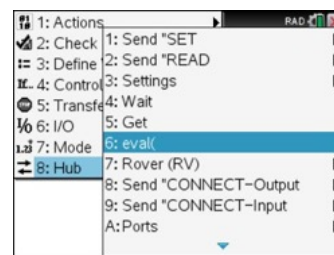

5. Eindig het programma met Wait 1.

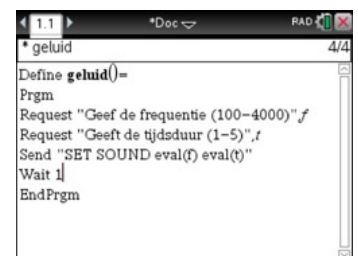
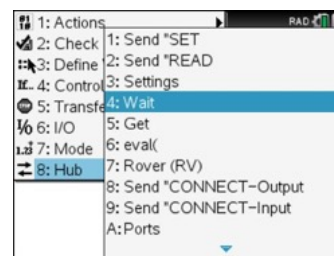

```
Define geluid()=
Prgm
  Request "Geef de frequentie (100-4000)",f
  Request "Geef de tijdsduur (1-5)",t
  Send "SET SOUND eval(f) eval(t)
EndPrgm
```



Geluid Maken



6. Bewaar het programma geluid en run het in een Calculator Applicatie.

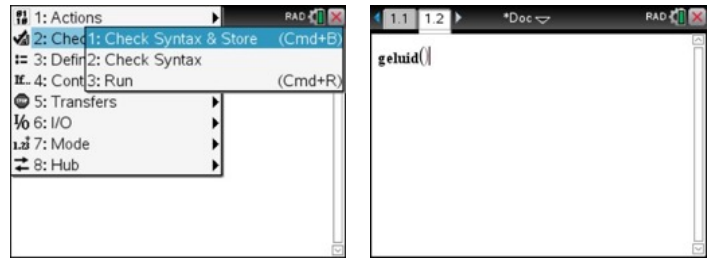

7. Extra

Gebruikmakend van lijsten en een For-lus, kan het programma geluid eenvoudig uitgebreid worden tot een deuntje.

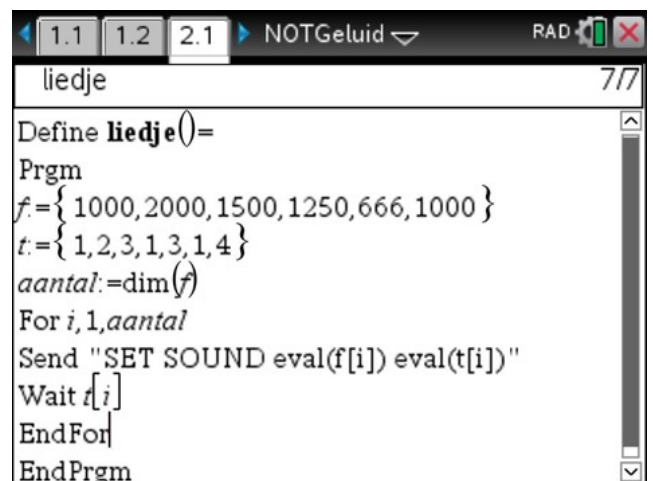

Define geluid()=

Prgm

Request "Geef de frequentie (100-4000)",f

Request "Geef de tijdsduur (1-5)",t

Send "SET SOUND eval(f) eval(t)

EndPrgm



LED in verschillende kleuren

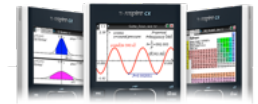

1. Creëer een nieuw programma color: druk Home (⌘), kies 1: New Document en vervolgens 9: Add Program Editor en 1:New.

2. Druk Menu > I/O > Request en voer de volgende code in:

```
Request "Rood (0-255)",r
Request "Groen (0-255)",g
Request "Blauw (0-255)",b
```

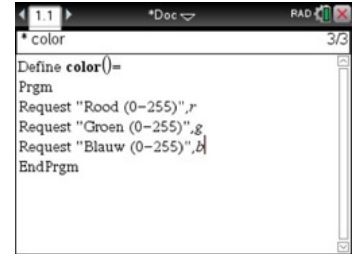
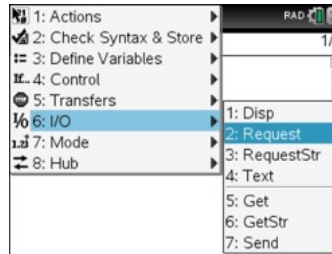

3. Druk Menu > Hub > Send "SET en selecteer COLOR.

```
Define color()=
Prgm
Request "Rood (0-255)",r
Request "Groen (0-255)",g
Request "Blauw (0-255)",b
Send "SET COLOR|"
EndPrgm
```

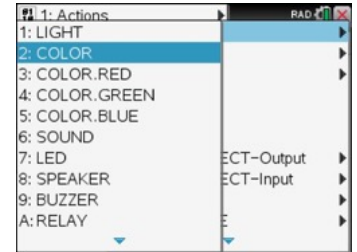
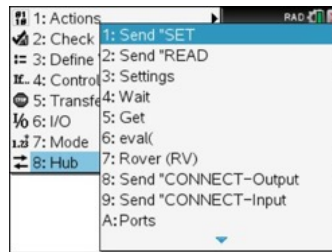

4. Selecteer eval(in het Hub-menu, type r en vul aan met eval(g) en eval(b).

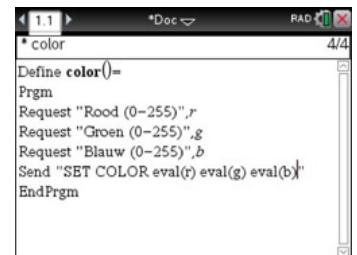
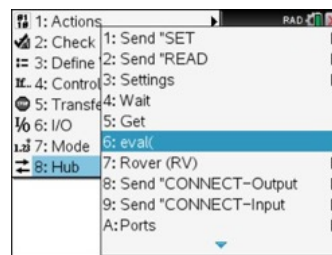

5. Selecteer vervolgens TIME in het submenu Settings van het Hub-menu en type 2.

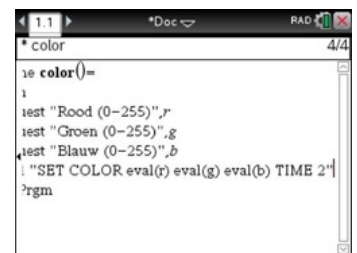
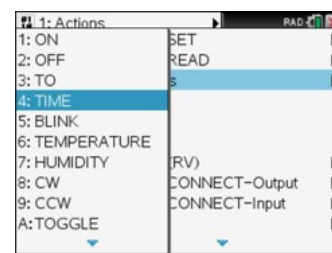

```
Define color()=
Prgm
Request "Blauw (0-255)",r
Request "Groen (0-255)",g
Request "Blauw (0-255)",b
Send "SET COLOR eval(r) eval(g) eval(b) TIME 2"
Wait 3
EndPrgm
```



LED in verschillende kleuren

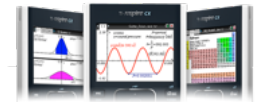

6. Eindig het programma met Wait 3.
7. Bewaar het programma color en run color in een Calculator Applicatie.

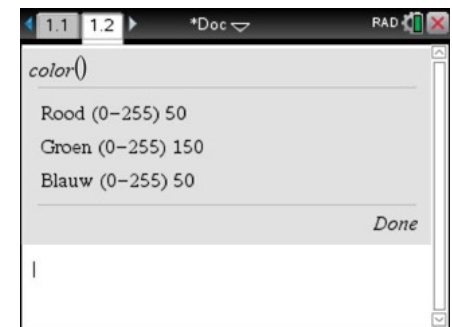
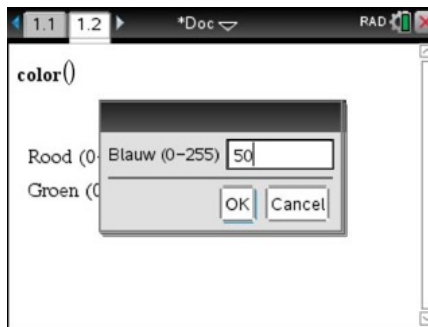
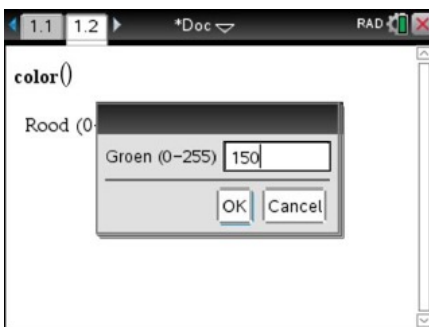
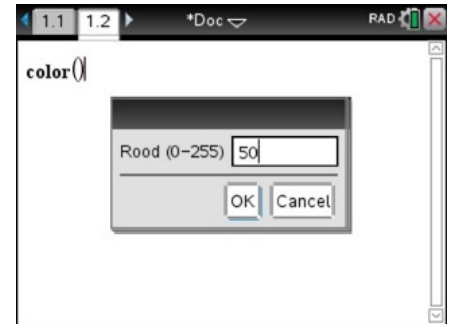
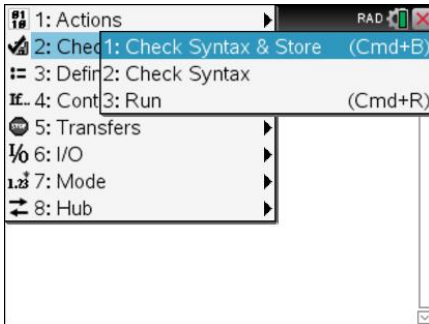
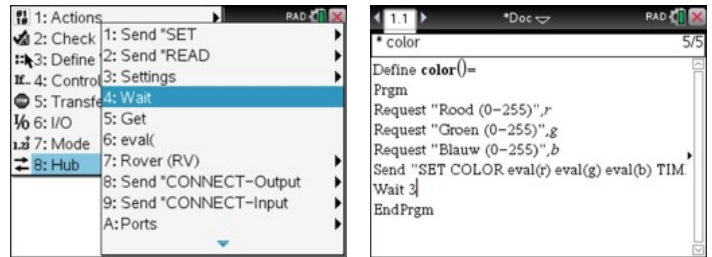

```

Define color()=
Prgm
Request "Blauw (0-255)",r
Request "Groen (0-255)",g
Request "Blauw (0-255)",b
Send "SET COLOR eval(r) eval(g) eval(b) TIME 2
Wait 3
EndPrgm
    
```



Lichtsensoren

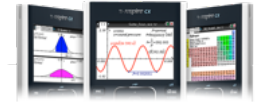

1. Creëer een nieuw programma licht: druk Home (🏠), kies 1: New Document en vervolgens 9: Add Program Editor en 1:New.

2. Druk Menu > Hub > Send "READ en selecteer BRIGHTNESS.

```
Define licht()=
Prgm
Send "READ BRIGHTNESS"
EndPrgm
```

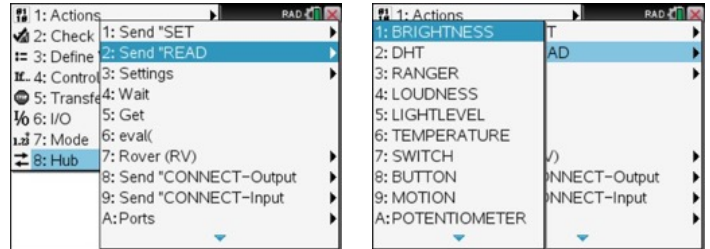

3. Selecteer In de Hub menu GET en type b.

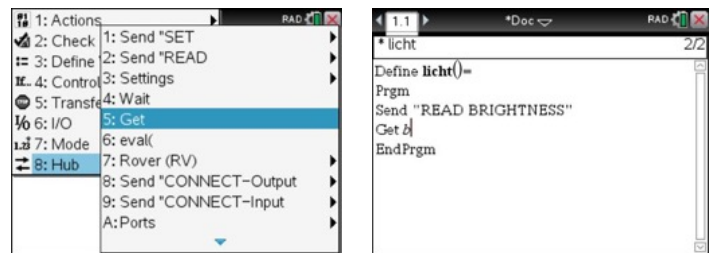

4. Druk Menu > I/O > Disp en voer de volgende code in:
Disp "De lichtsterkte is: ",b

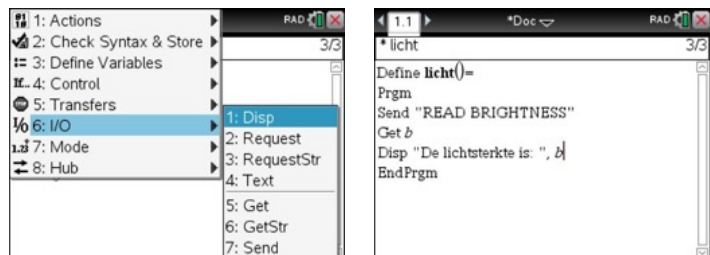

5. Bewaar het programma licht en run licht in een Calculator Applicatie.

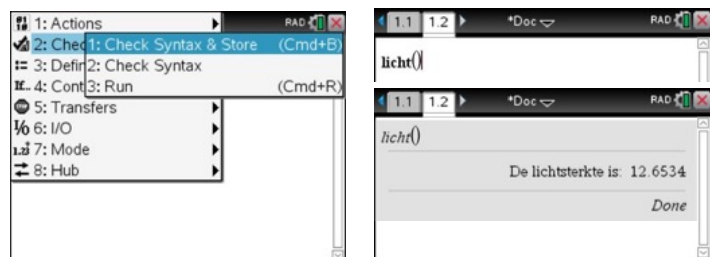

```
Define licht()=
Prgm
Send "READ BRIGHTNESS"
GET b
Disp "De lichtsterkte is: ",b
EndPrgm
```



Knipperend LED

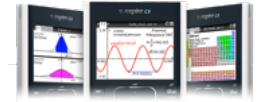

Monteer een LED (Light Emitting Diode) zoals aangegeven in het onderstaande diagram. Een diode heeft de eigenschap dat de stroom slechts in één richting wordt doorgelaten; polariteit. Er kan alleen stroom lopen van de *anode* (positieve pool) naar de *kathode* (negatieve pool).

Sluit het elektrisch circuit aan op BB 1 (Bread Board connectie 1) zoals hieronder aangegeven.

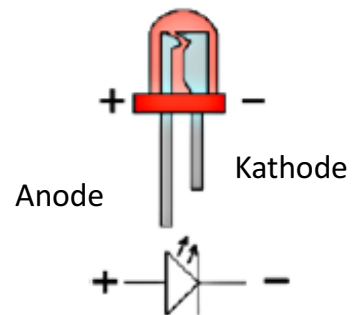
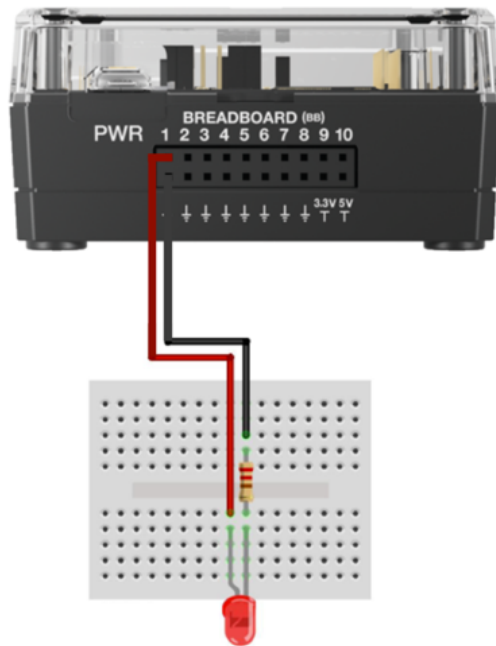

Codeer communicatie tussen het bread board en de TI-Innovator Hub als volgt:

1. Creëer een nieuw programma led: druk Home (🏠), kies 1: New Document en vervolgens 9: Add Program Editor en 1:New.
2. Druk Menu > Hub > Send "CONNECT-Output, selecteer LED en type 1. De LED zal aanstuurbaar zijn via de naam LED 1.

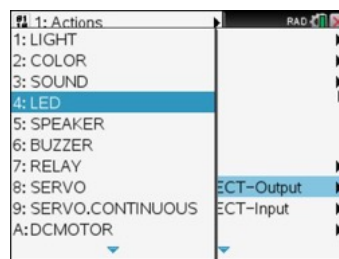
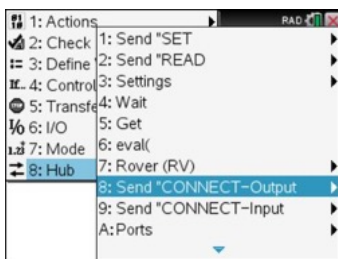

```
Define led()=  
Prgm  
Send "CONNECT LED 1"  
EndPrgm
```



Knipperend LED

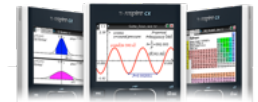

3. In de volgende stap laten we de TI-Innovator weten via welke poort de communicatie gebeurt. Druk Menu > Hub > Ports > BB1.

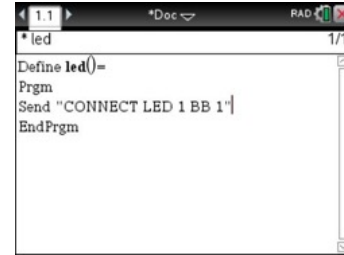
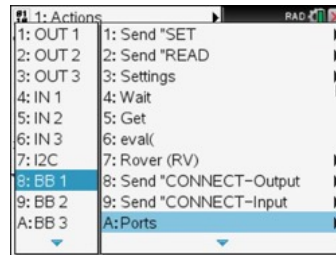
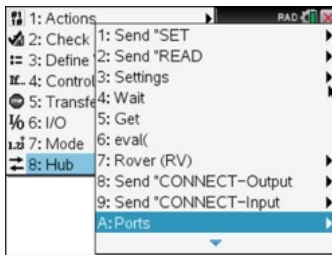

4. Druk Menu > Hub > Send "SET", selecteer LED en type 1.

```
Define led()=
Prgm
Send "CONNECT LED 1 BB 1"
Send "SET LED 1"
EndPrgm
```

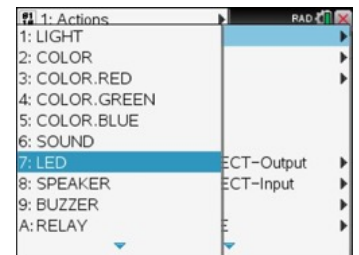
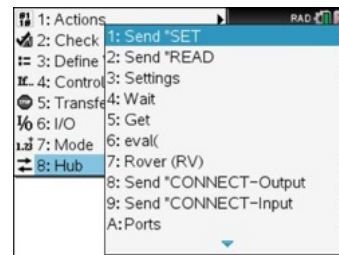

5. Selecteer in het Hub-submenu Settings ON, selecteer dan BLINK en type 10 en vervolg met TIME 1 en Wait 2.

```
Define led()=
Prgm
Send "CONNECT LED 1 BB 1"
Send "SET LED 1 ON BLINK 10 TIME 1 "
Wait 2
EndPrgm
```

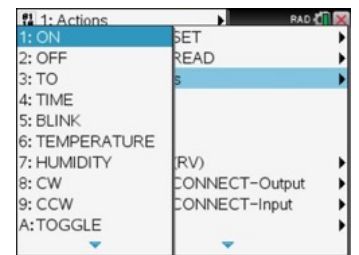
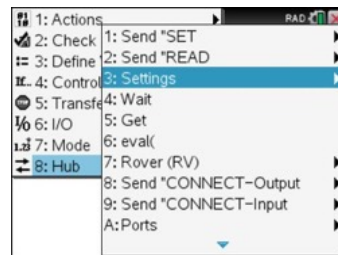

6. Doe de LED uit met Send "SET LED 1 OFF" en eindig met (Menu > Hub >) Send "DISCONNECT-Output LED 1" .

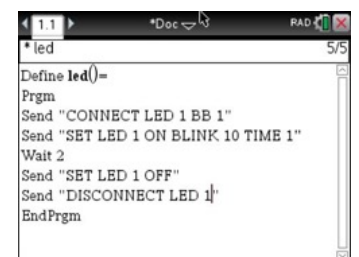

7. Bewaar (CTRL B) het programma led en run led() in a Calculator Application

```
Define led()=
Prgm
Send "CONNECT LED 1 BB 1"
Send "SET LED 1 ON BLINK 10 TIME 1 "
Wait 2
Send "SET LED 1 OFF"
Send "DISCONNECT LED 1"
EndPrgm
```



Inspiring Generation STEM

There is a mathema**T**ician and scien**T**ist in every student

